



Roller Guides for Lift Engineering

including
Spare Parts for complete
Roller Guides

Contents		Page
Practicable Roller Guides for Lift Engineering		3
Roller Guide AR 0.1	Roller Guide AR 0	4 / 5
Roller Guide AR 1	Roller Guide AR 1B	6 / 7
Roller Guide AR 3	Angled Roller Guide ARW 2	8 / 9
Spring loaded Roller Guide AR 1F	Spring loaded Roller Guide AR 3F	12 / 13
Roller Sliding Guide HSM RG	Roller Sliding Guide HSML RG	14 / 15
Rollers and Spare Parts for other Roller Guides		18 / 19

ACLA-Roller Guides are distinguished by a thought-out design

The ACLA-RollerGuide program consisting of many roller guides and roller sliding guides is designed for high-speed electric and hydraulic lifts.

With the roller guides the construction principle of eccentrically adjustable king pins and oblong holes enable a correct adaption to the existing rail. Depending on type of roller guide an infinitely variable adjustment to rail widths from 4 to 36 mm is possible in an easy way by means of a fixed spanner or socket wrench.

The base supports made of special alloy or steel assure an excellent stability of the complete roller guide units.

Exact dimensioning of the rollers used

The experience of ACLA-WERKE in lift engineering for many years and the know-how as manufacturer of high-quality polyurethane elastomers enable our technicians to achieve an exact dimensioning of the rollers used for the individual application.

In combination with the choice of the appropriate polyurethane elastomer the ACLA rollers proved successfully in roller guide units with excellent load values on a worldwide scale.

Rollers of ACLATHAN®

The premounted rollers of the high-quality polyurethane elastomer ACLATHAN for the lift industry offer the following advantages for the application:

- low rolling resistance
- high loading capacity
- excellent abrasion and wear resistance
- low oscillation on account of high concentricity
- silent running
- maintenance-free
- oil-resistant
- minimum compression set (flattening) after temporary standstill



type: AR 0.1

ACLA-Roller Guides are deliverable with roller dias. from 40 to 200 mm



type: AR 3

Roller Guide AR 0.1

ø 40 x 15

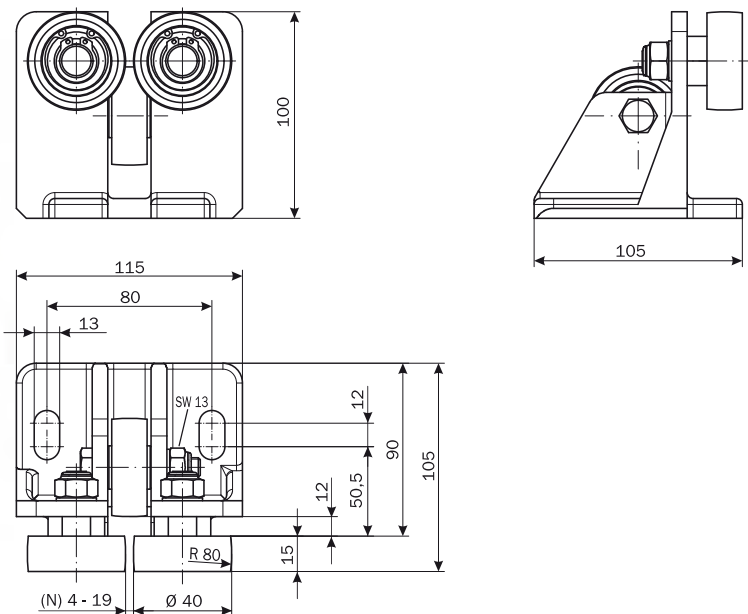
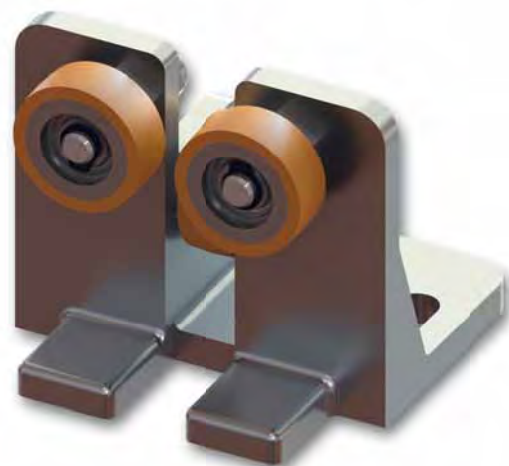

Design Details

- Infinitely adjustable to rail width from 4 to 19 mm in no time.
- King pins adjustable in the oblong holes, SW 19

art. no.	rollers ø D x b	complete weight approx. kg	*max. load [N] per roller with v nominal [m/s]		
			0,63	1,0	2,5
142294.04	40 x 15	1,15	630	600	570

*Information as to load: The load of the central roller decreases depending on the relation between rails and roller width.

Spare Parts for Roller Guide AR 0.1

Gauge Roller (FF1 Roller)

(with bushings, screw, lock washer and locking nut)



ø 40 x 15 = art. no. 142 293.05

FF1/FF2 Roller

(may be used in rear and front)



ø 40 x 15 = art. no. 142 293.03

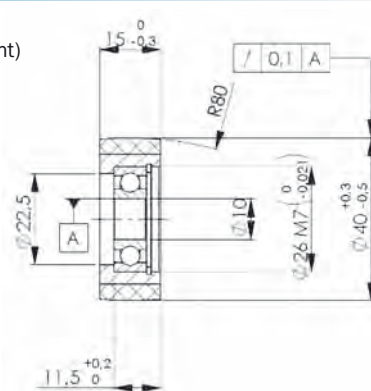

Roller Guide AR 0

ø 50 x 18 to ø 70 x 18

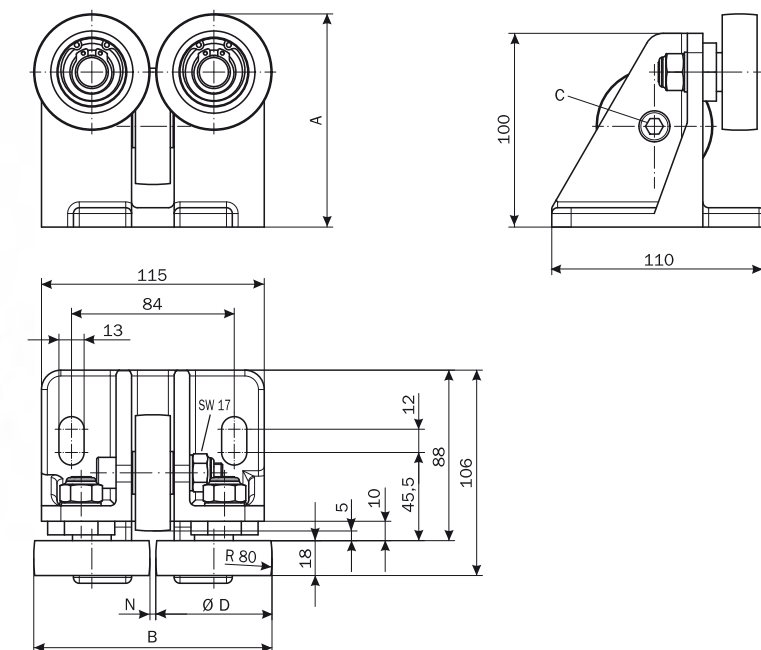
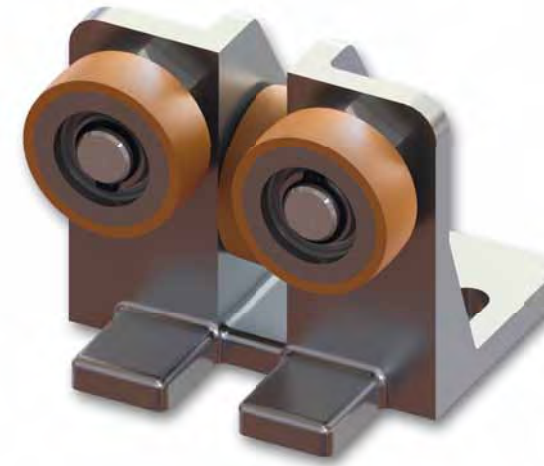

Design Details

- Infinitely adjustable to rail width from 5 to 25 mm in no time.
- Excentrically adjustable king pins, SW 30

art. no.	rollers ø D x b	complete weight approx. kg	*max. load [N] per roller with v nominal [m/s]			mounting dimensions		
			0,63	1,0	2,5	A	B	N
142042.04	50 x 18	1,3	1.000	960	900	max. 110,5	max. 126	5 - 25
142 043.04	60 x 18	1,35	1.200	1.100	1.050	max. 115,5	max. 141	5 - 20
142 044.04	70 x 18	1,42	1.300	1.250	1.200	max. 120,5	max. 161	5 - 20

*Information as to load: The load of the central roller decreases depending on the relation between rails and roller width.

Spare Parts for Roller Guide AR 0

Gauge Roller (FF1 Roller)

(with bushings, screw, lock washer and locking nut)

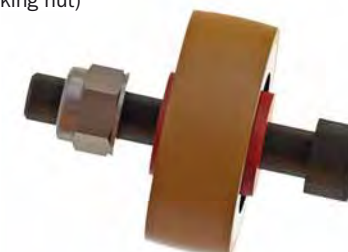

ø 50 x 18 = art. no. 142 062.05
ø 60 x 18 = art. no. 142 064.07
ø 70 x 18 = art. no. 142 065.07

FF1/FF2 Roller

(may be used in rear and front)



ø 50 x 18 = art. no. 142 062.01
ø 60 x 18 = art. no. 142 064.04
ø 70 x 18 = art. no. 142 065.02

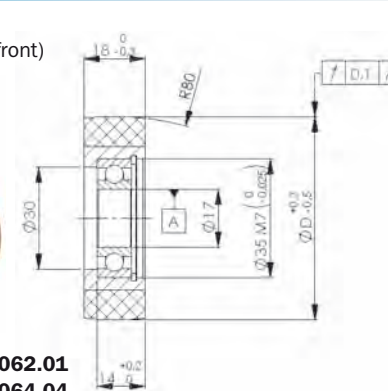

Side Roller (FF2 Roller)

(with excentric bolt, lock washer and locking nut)



ø 40 x 15 = art. no. 142 293.04

Side Roller (FF2 Roller)

(with excentric bolt, lock washer and locking nut)



ø 50 x 18 = art. no. 142 062.03
ø 60 x 18 = art. no. 142 064.05
ø 70 x 18 = art. no. 142 065.04

Roller Guide AR 1

Ø 80 x 25 to Ø 125 x 25

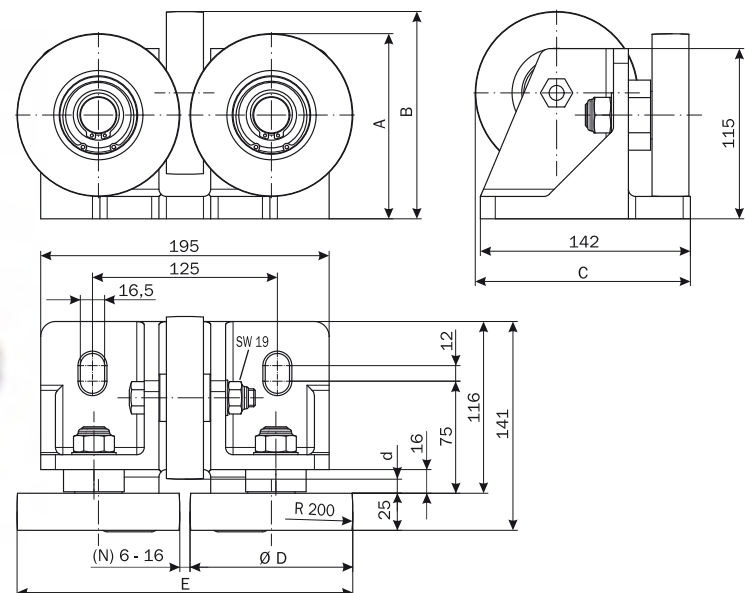

Design Details

- Infinitely adjustable to rail width from **6 to 16 mm** in no time.
- Excentrically adjustable king pins, SW 41

art. no.	rollers Ø D x b	no. of ball bearings	complete weight approx. kg	*max. load [N] per roller with v nominal [m/s]			mounting dimensions				
				0,63	1,0	2,5	A	B	C	d	E
141 895.04	80 x 25	1	3,6	1.830	1.790	1.480	max. 103	130	110	4	max. 177
141 896.04	100 x 25	2	5,1	2.360	2.310	1.910	max. 123	135	130	4	max. 217
141 897.04	125 x 25	2	7,1	3.120	2.980	2.570	max. 149	146	153	2	max. 267

*Information as to load: The load of the central roller decreases depending on the relation between rails and roller width.

Spare Parts for Roller Guide AR 1 with 2 Bearings per single Roller

Gauge Roller (FF1 Roller)
(with bushings, screw,
lock washer and locking nut)

Ø 100 x 25 = art. no. 142 082.03
Ø 125 x 25 = art. no. 142 081.02



Side Roller (FF2 Roller)
(with excentric bolt,
lock washer and locking nut)

Ø 100 x 25 = art. no. 142 082.02
Ø 125 x 25 = art. no. 142 081.01



FF1/FF2 Roller
(may be used in rear and front)

Ø 100 x 25 = art. no. 141 863.08
Ø 125 x 25 = art. no. 141 868.02

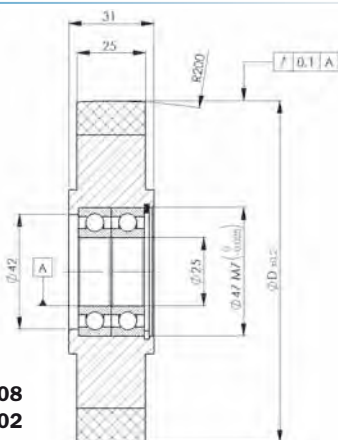

Spare Parts for Roller Guide AR 1 with 1 Bearing per single Roller

Gauge Roller (FF1 Roller)
(with bushings, screw,
lock washer and locking nut)

Ø 80 x 25 = art. no. 142 083.04
Ø 100 x 25 = art. no. 142 082.04
Ø 125 x 25 = art. no. 142 081.03

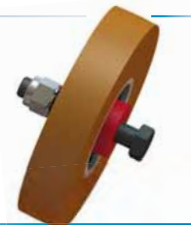

Side Roller (FF2 Roller)
(with excentric bolt,
lock washer and locking nut)

Ø 80 x 25 = art. no. 142 083.02
Ø 100 x 25 = art. no. 142 082
Ø 125 x 25 = art. no. 142 081



FF1/FF2 Roller
(may be used in rear and front)

Ø 80 x 25 = art. no. 141 867.06
Ø 100 x 25 = art. no. 141 863.09
Ø 125 x 25 = art. no. 141 868.03

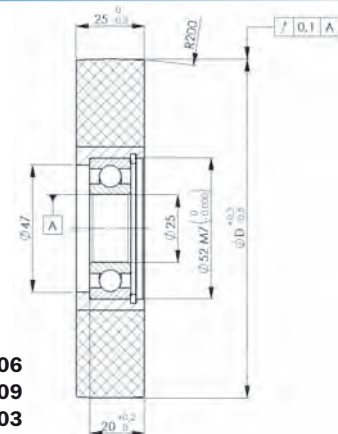
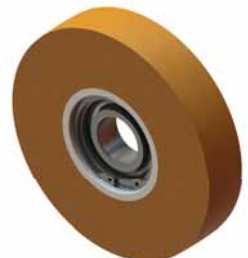

Roller Guide AR 1B

Ø 125 x 30 side rollers
Ø 120 x 30 central roller

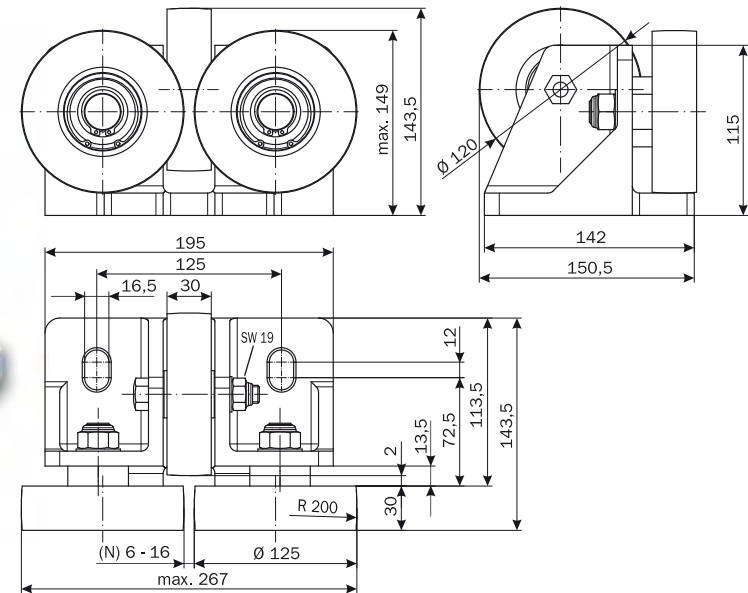
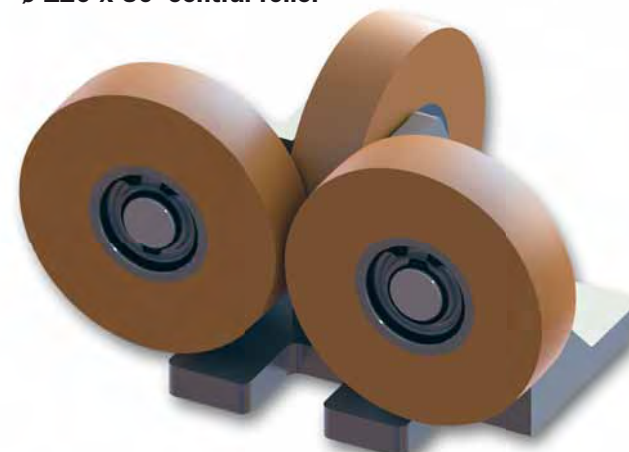

Design Details

- Infinitely adjustable to rail width from **6 to 16 mm** in no time.
- Excentrically adjustable king pins, SW 41

art. no.	rollers Ø D x b	no. of ball bearings	complete weight approx. kg	*max. load [N] per roller with v nominal [m/s]		
				0,63	1,0	2,5
142 621.04	125 x 30 (2 x side roller)	1	4,5	3.300	3.100	2.800
	120 x 30 (1 x central roller)	1		2.790	2.730	2.330

*Information as to load: The load of the central roller decreases depending on the relation between rails and roller width.

Spare Parts for Roller Guide AR 1B

FF1 Roller
(only be used in rear)

Ø 120 x 30 = art. no. 140 773.06

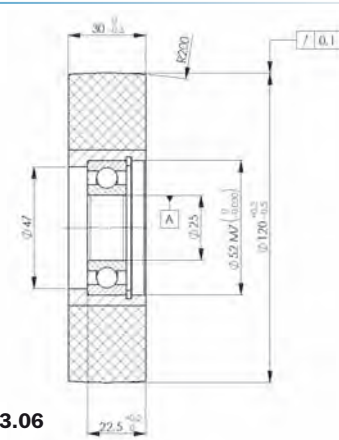
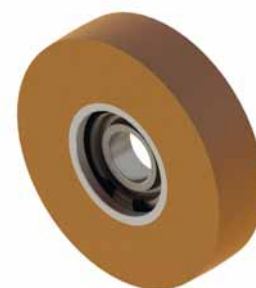

FF2 Roller
(only be used in front)

Ø 125 x 30 = art. no. 140 776.06

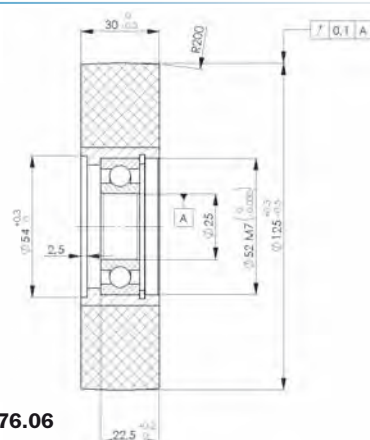

Side Roller (FF2 Roller)
(with excentric bolt,
lock washer and locking nut)

Ø 125 x 30 = art. no. 140 776.08



Roller Guide AR 3

ø 148 x 40 to ø 200 x 40

Also available as „special execution“ with particularly high-quality installation components.

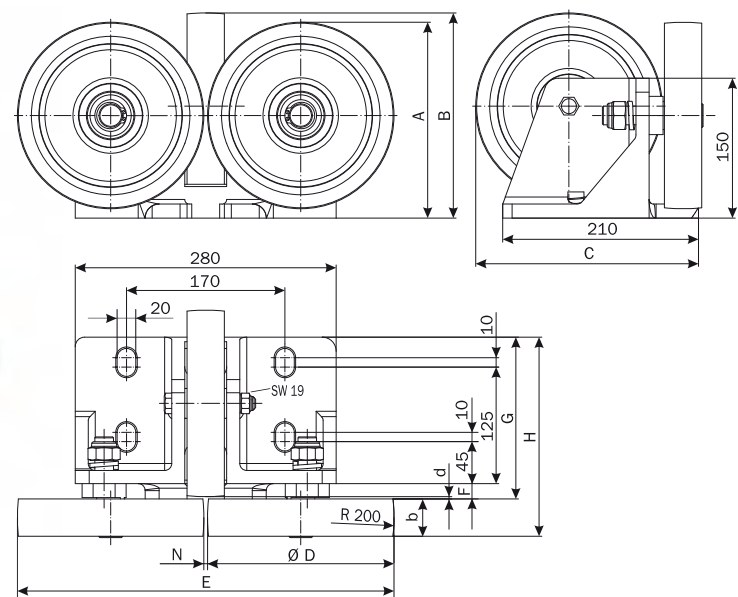

Design Details

- Infinitely adjustable to rail width from 4 to 36 mm in no time.
- Excentrically adjustable king pins, SW 41

art. no.	rollers Ø D x b	complete weight approx. kg	no. of ball bearings	*max. load [N] per roller with v nominal [m/s]				mounting dimensions								
				0,63	1,0	2,5	4	A	B	C	d	E	N	F	G	H
142 836.04	148 x 40	12	2	5.460	5.140	3.990	2.900	max. 176	169	188	4,5	max. 330	6 - 34	17,5	172,5	212,5
142 380.04	179 x 35	13	2	5.150	4.990	4.310	3.000	max. 207	200	219	4,5	max. 396	10 - 36	18,5	175,5	210,5
142 389.04	200 x 40	16	2	6.300	6.090	5.250	3.700	max. 217	220	239	2,5	max. 432	4 - 32	16,5	173,5	213,5

*Information as to load: The load of the central roller decreases depending on the relation between rails and roller width.

Spare Parts for Roller Guide AR 3

Gauge Roller (FF1 Roller)

(with bushings, screw, lock washer and locking nut)



ø 148 x 40 = art. no. 141 955.10
ø 179 x 35 = art. no. 142 416.07
ø 200 x 40 = art. no. 142 417.07

FF1/FF2 Roller

(may be used in rear and front)



ø 148 x 40 = art. no. 141 955.05
ø 179 x 35 = art. no. 142 416.04
ø 200 x 40 = art. no. 142 417.04

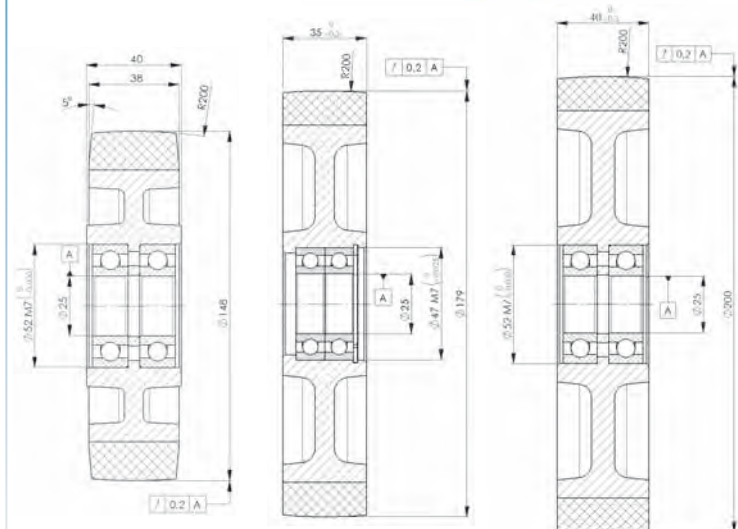

Side Roller (FF2 Roller)

(with excentric bolt, lock washer and locking nut)



ø 148 x 40 = art. no. 141 955.08
ø 179 x 35 = art. no. 142 416.05
ø 200 x 40 = art. no. 142 417.05

Angled Roller Guide ARW 2

ø 80 x 20

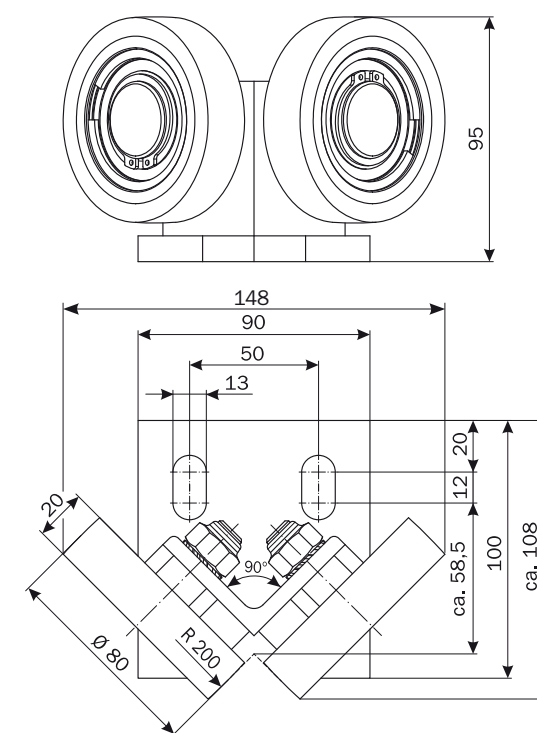
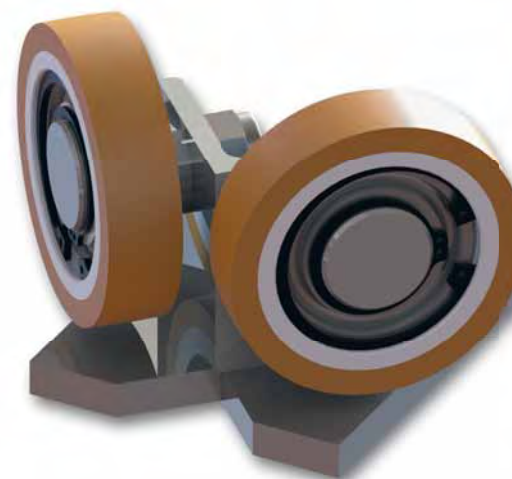

Design Details

- for angled rails and rondles

art. no.	rollers Ø D x b	complete weight approx. kg	max. load [N] per roller with v nominal [m/s]		
			0,63	1,0	2,5
142 993.04	80 x 20	2,0	1.580	1.370	1.050

Spare Parts for Roller Guide ARW 2

Single Roller

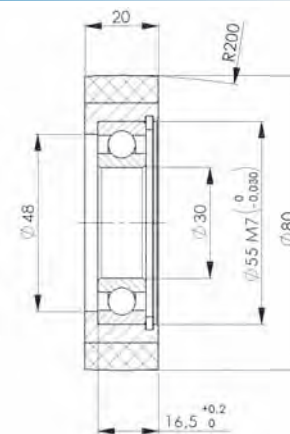
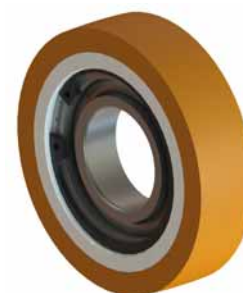

ø 80 x 20 = art. no. 140 419.04

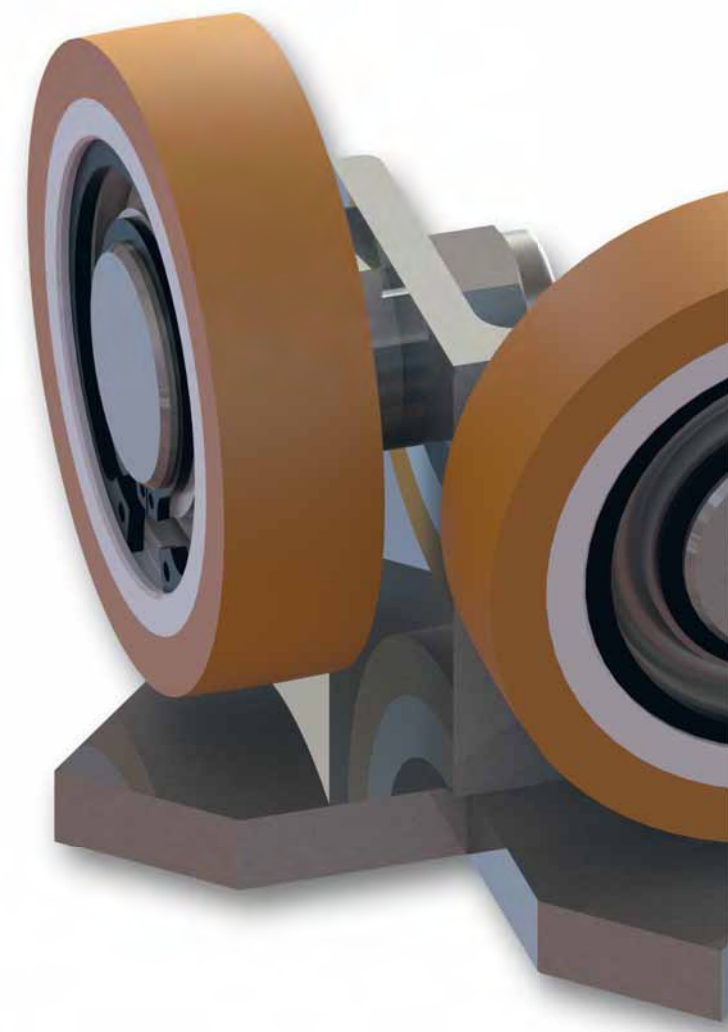

**ACLA Roller Guides:
well conceived construction to the detail**

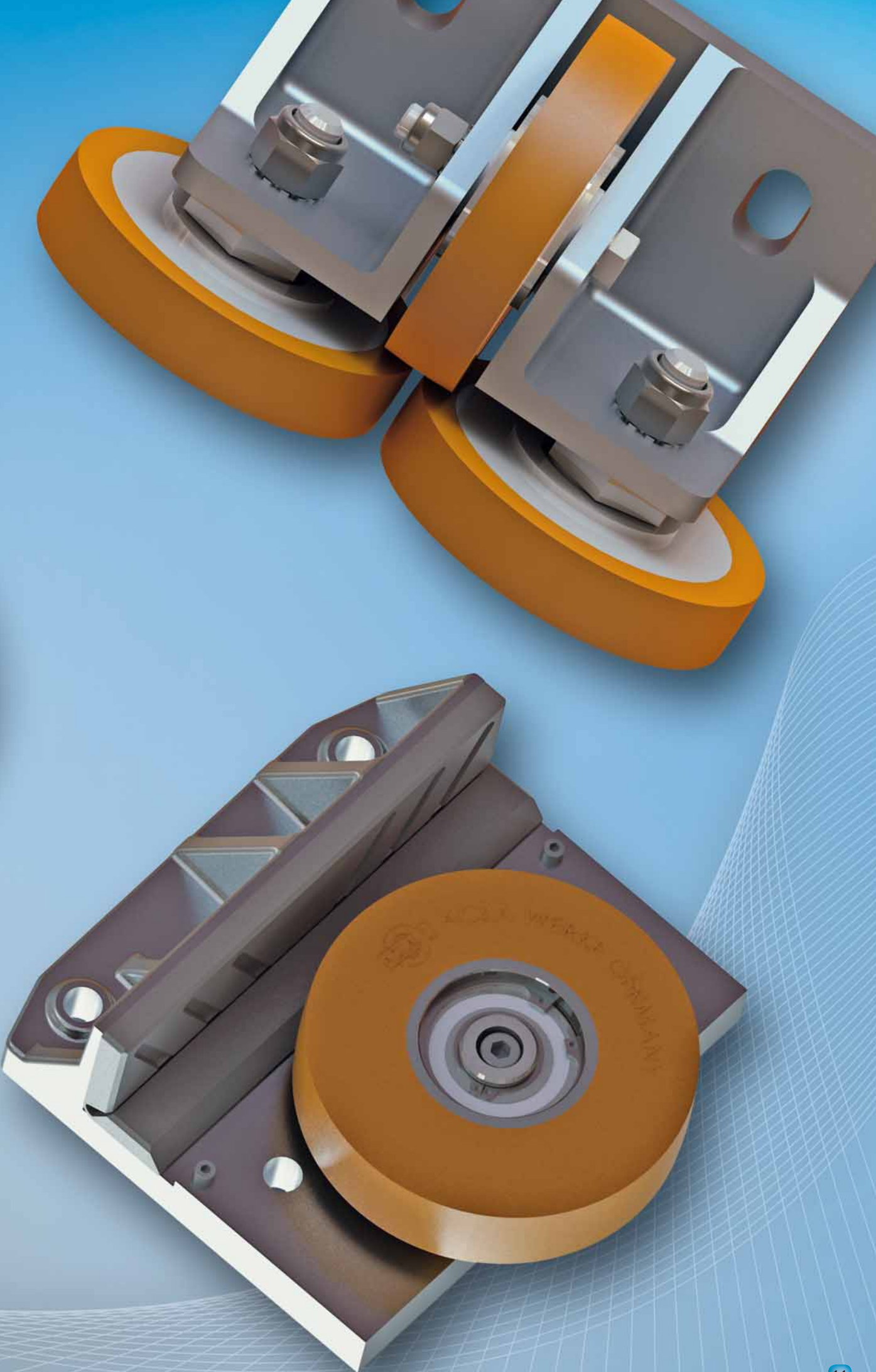

Spring loaded Roller Guide AR 1F

ø 100 x 25

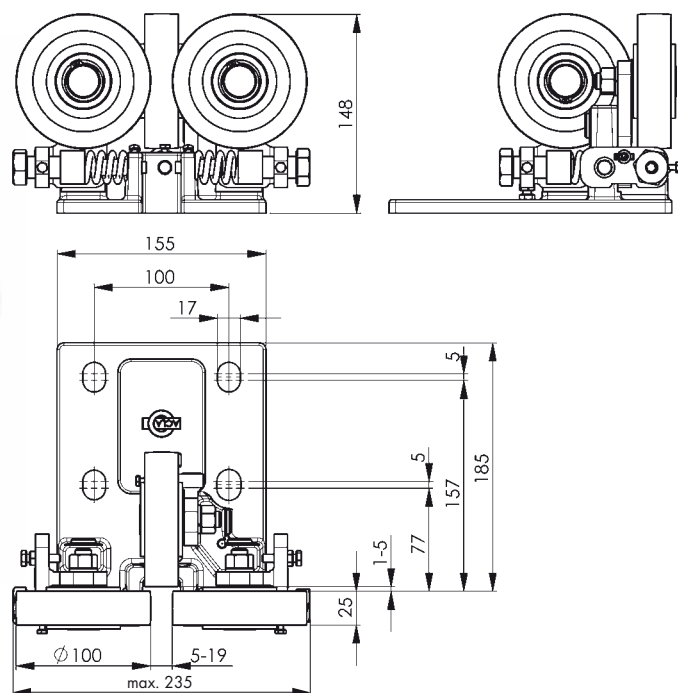
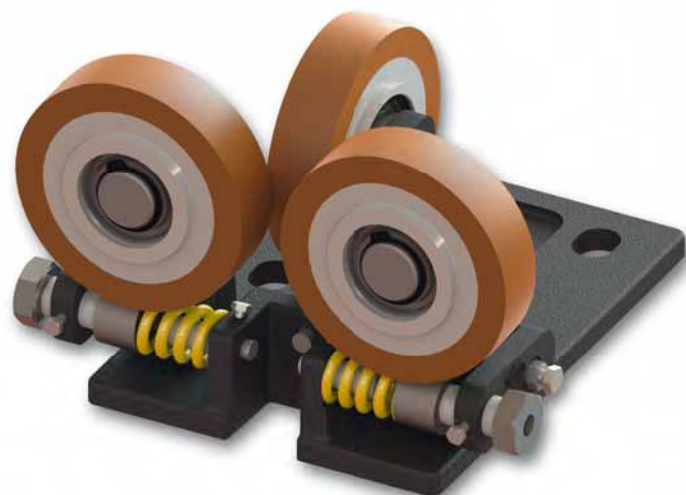

Design Details

- Infinitely adjustable to rail width from **5 to 19 mm** in no time
- Spring stroke and emergency stops are adjustable
- A wide range of springs is applicable (see table below)
- Due to the execution in steel cast the breaking load of the support is considerably higher than for the Aluminium die casts supports
- Each roller is equipped with two ball bearings

art. no.	rollers ø D x b	complete weight approx. kg	*max. load [N] per roller with v nominal [m/s]		
			0,63	1,0	2,5
pls. see table on the right	100 x 25	8,2	2.260	2.210	1.820

*Information as to load: The load of the central roller decreases depending on the relation between rails and roller width.

Spring configuration					
spring	SWB 25-30	SWH 25-30	SWM 25-30	SWL 25-31	SWF 25-32
hardness	extremely hard	hard	middle	soft	extremely soft
spring rate	400 N/mm	255 N/mm	128 N/mm	69 N/mm	33 N/mm
colour	brown	green	red	blue	yellow
art. no.	143 284	143 284.02	143 284.01	143 284.03	143 284.04

Spare Parts for Roller Guide AR 1F

Single Roller

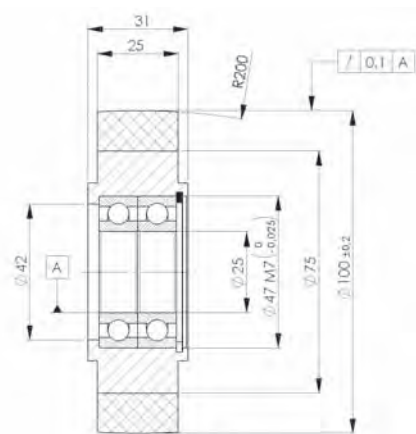

ø 100 x 25 = art. no. 141 863.08

Spring loaded Roller Guide AR 3F

ø 148 x 20

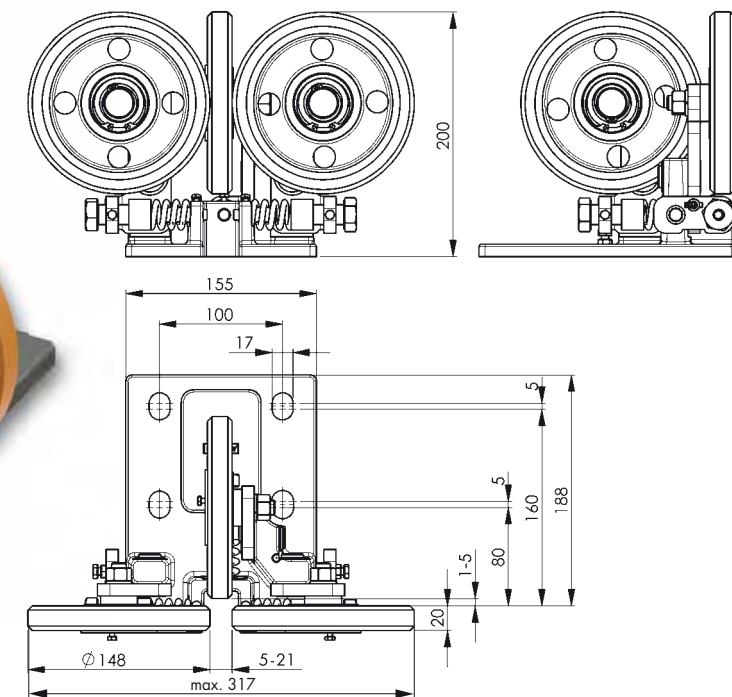

Design Details

- Infinitely adjustable to rail width from **5 to 21 mm** in no time
- Spring stroke and emergency stops are adjustable
- A wide range of springs is applicable (see table below)
- Due to the execution in steel cast the breaking load of the support is considerably higher than for the Aluminium die casts supports
- Each roller is equipped with two ball bearings

art. no.	rollers ø D x b	complete weight approx. kg	*max. load [N] per roller with v nominal [m/s]		
			0,63	1,0	2,5
pls. see table on the right	148 x 20	9,9	3.190	3.000	2.330

*Information as to load: The load of the central roller decreases depending on the relation between rails and roller width.

Spring configuration					
spring	SWB 25-30	SWH 25-30	SWM 25-30	SWL 25-31	SWF 25-32
hardness	extremely hard	hard	middle	soft	extremely soft
spring rate	400 N/mm	255 N/mm	128 N/mm	69 N/mm	33 N/mm
colour	brown	green	red	blue	yellow
art. no.	143 448	143 448.02	143 448.03	143 448.04	143 448.05

Spare Parts for Roller Guide AR 3F

Single Roller

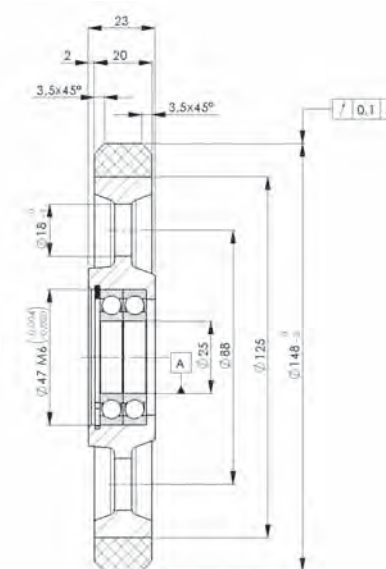

ø 148 x 20 = art. no. 142 997.01

Roller Sliding Guide HSM RG

with roller $\varnothing 80 \times 20$

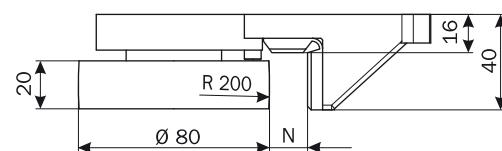
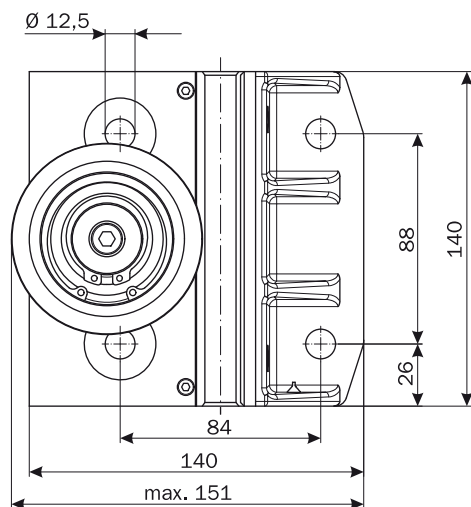
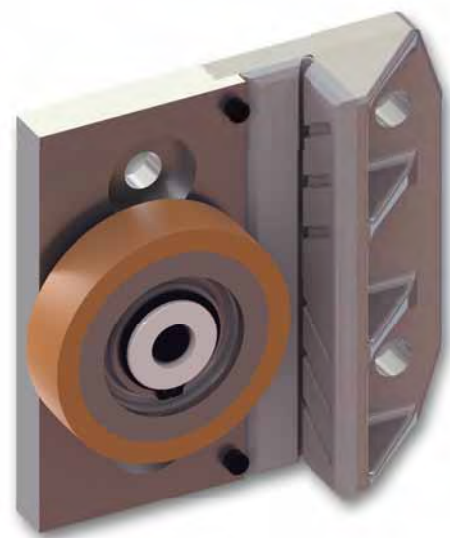

Design details

- Aluminium guide shoe with half a guide shoe insert of ACLASYN GR as sliding guide
- For rail widths of 5, 9 and 16 mm

art. no.	rail width [mm]	rollers $\varnothing D \times b$	complete weight approx. kg	max. load [N] per roller with v nominal [m/s]		
				0,63	1,0	2,5
142 988.04	16	80 x 20	1,1	1.580	1.370	1.050
142 988.05	9	80 x 20	1,1	1.580	1.370	1.050
142 988.06	5	80 x 20	1,1	1.580	1.370	1.050

Mounting instruction: Between roller/sliding guide and rail a gap of 0,1 to 0,5 mm is to be considered.

Spare Parts for Roller Guide HSM RG

Single Roller

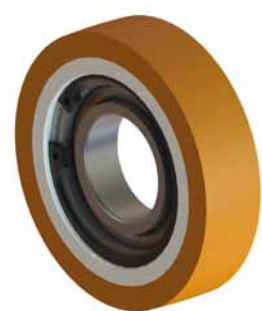

$\varnothing 80 \times 20 =$ art. no. 140 419.04

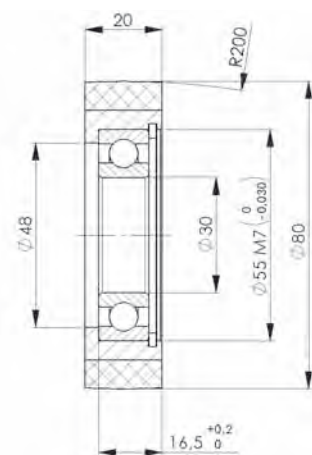

Insert



Rail width 16 mm (t = 6,4)
art. no. 200 269

Rail width 9 mm (t = 9,8)
art. no. 200 360

Rail width 5 mm (t = 11,8)
art. no. 200 361

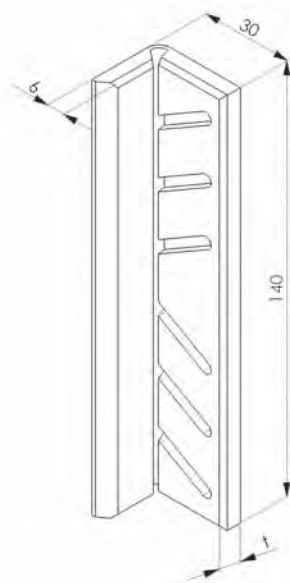

Roller Sliding Guide HSML RG

with roller $\varnothing 100 \times 30$ or $\varnothing 125 \times 30$

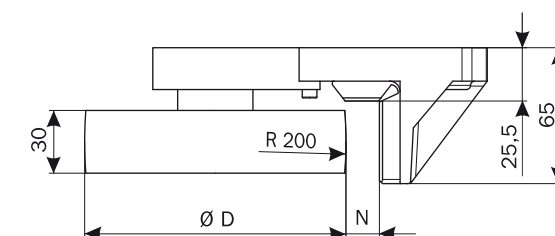
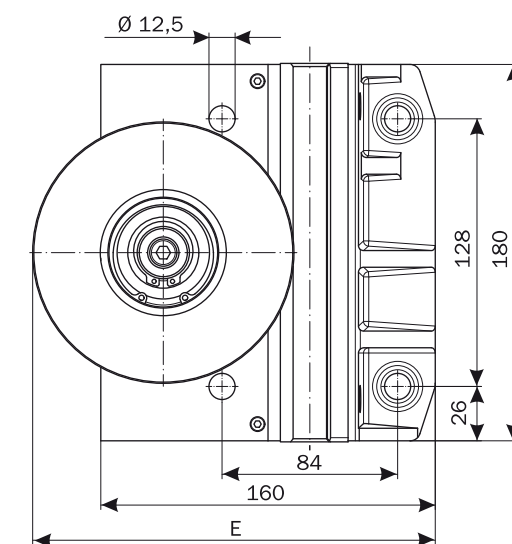

Design details

- Aluminium guide shoe with half a guide shoe insert of ACLASYN GR as sliding guide
- For rail widths from 5 to 19 mm

art. no.	rollers $\varnothing D \times b$	complete weight approx. kg	max. load [N] per roller with v nominal [m/s]			mounting dimensions E
			0,63	1,0	2,5	
142 987.04	100 x 30	2,1	2.730	2.520	2.100	max. 195
142 786.04	125 x 30	2,3	3.300	3.100	2.800	max. 182,5

Mounting instruction: Between roller/sliding guide and rail a gap of 0,1 to 0,5 mm is to be considered.

Spare Parts for Roller Guide HSML RG

Single Roller

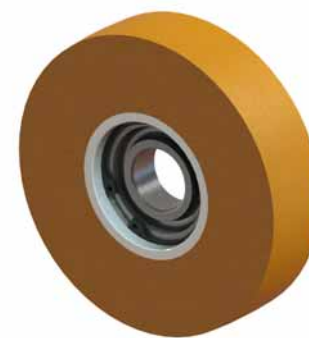

$\varnothing 100 \times 30 =$ art. no. 141 915.02
 $\varnothing 125 \times 30 =$ art. no. 140 776.06

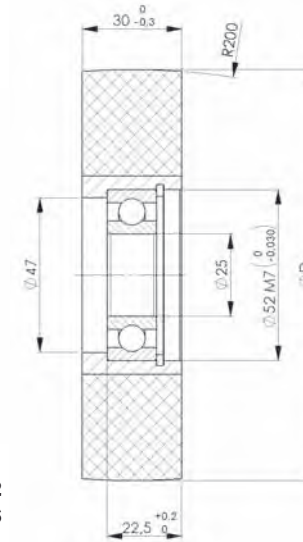

Insert



Rail width 5 - 19 mm
art. no. 200 270



Focus on quality in ACLA production processes



Rollers and Spare parts for other Roller Guides

Roller: ϕ 70 x 25
art. no. 140 418.05

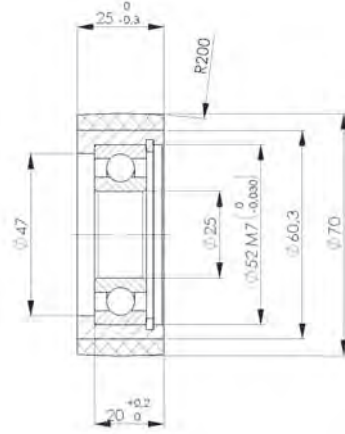

Roller: ϕ 75 x 20
art. no. 140 653

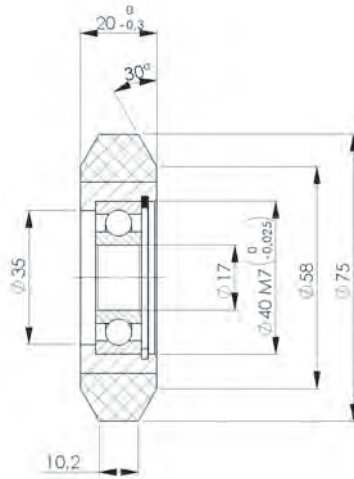

Roller: ϕ 79 x 25
art. no. 141 867.09

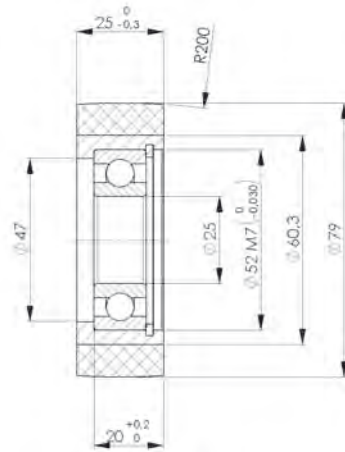

Roller: ϕ 100 x 25
art. no. 143 319

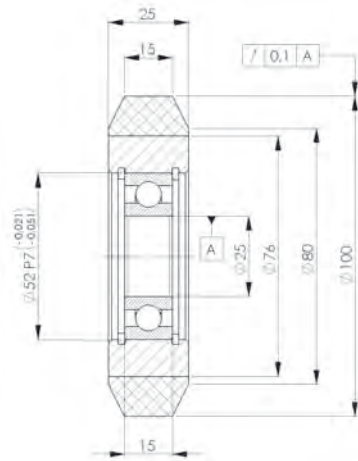

Roller: ϕ 110 x 25
art. no. 143 319.05

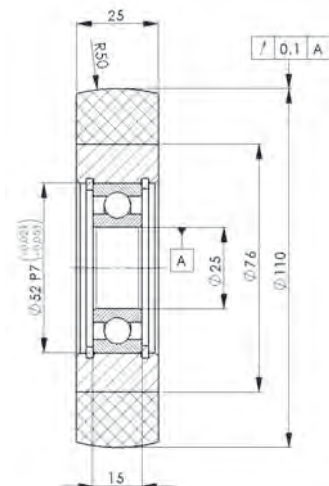

Roller: ϕ 120 x 30
art. no. 142 060

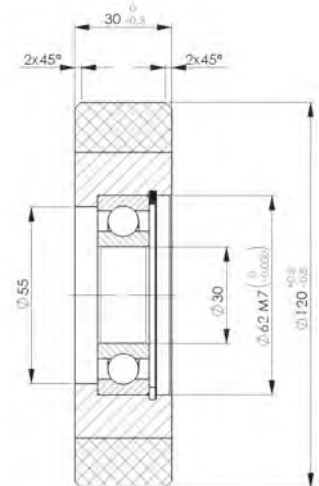

Rollers and Spare parts for other Roller Guides

Roller: ϕ 125 x 30

art. no. 140 856
(standard ball bearings)

art. no. 140 856.01
(SKF ball bearings)

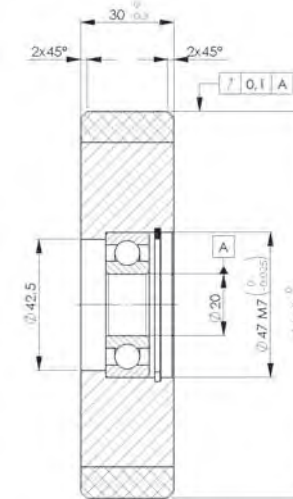

Roller: ϕ 300 x 30/34
art. no. 141 693.03

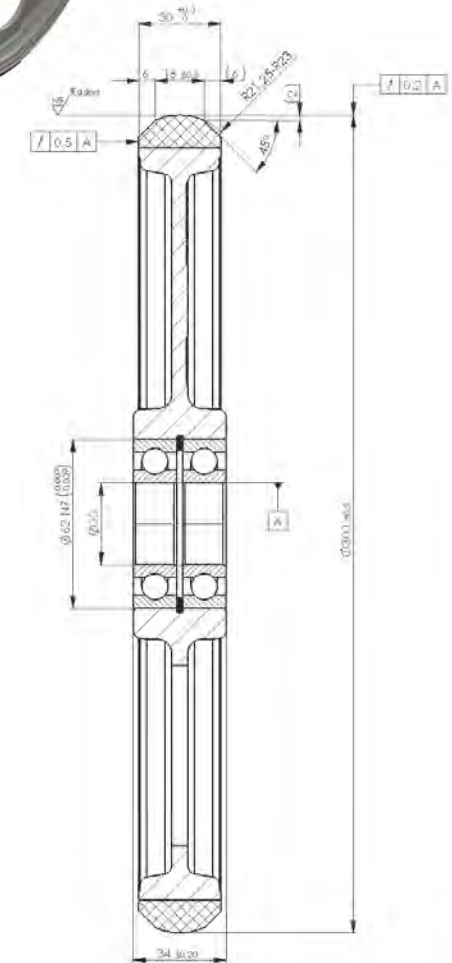

Roller: ϕ 150 x 30/32
art. no. 143 248

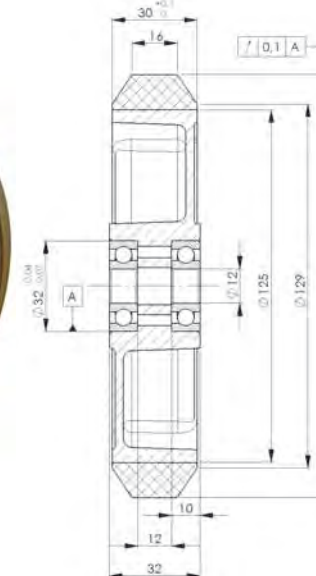



ACLA-WERKE GMBH

Frankfurter Str. 142-190 · 51065 Köln · Germany · Tel. +49(0)221/69998-0 · Fax +49(0)221/697121 · e-mail: info@acla-werke.de · www.acla-werke.de

ACLA USA, INC.

509 Thomson Park Drive · Cranberry TWP, PA 16006 · Tel. +1 724 / 7 76 00 99 · Fax +1 724 / 7 76 04 77 · e-mail: michael.ross@aclausa.com

ACLA FRANCE POLYURETHANE S.A.R.L.

Z.A. de la Fontaine des Tournelles · F-77230 Saint-Mard · Tel. +33 (0)1 64 02 77 87 · Fax +33 (0)1 64 02 79 27 · e-mail: acla.france@wanadoo.fr

Dimensions in mm. We reserve the right to change sizes. Further dimensions and special types on request. Our verbal or written recommendations for any application as well as tests are carried out to the best of our knowledge. They are without engagement also as far as patent rights of third parties are concerned, and do not exempt you from checking the products supplied by us to their suitability for the intended procedure and purpose. Application, use and processing of the products are outside our control, and are exclusively the responsibility of the customer. Moreover our general sales conditions apply.

© ACLA-WERKE GMBH. Printed in Germany. All figures are protected in copyright matters. Each duplication requires the agreement of ACLA-WERKE GMBH, 51065 Cologne/Germany.